



# SUNGARD ANALYSTS' DAY

BOSTON | DECEMBER 6, 2010



TRANSPARENCY • EFFICIENCY • NETWORKS

WHAT'S YOUR POSITION?

**SUNGARD**<sup>®</sup>

TEN IN PRACTICE

## Delivering on the "as a Service" Promise

Clare Porter, SVP Business Development, Infinity

Marc Gille, SVP Product Management, Infinity

**SunGard**



# Welcome and Update

---



# Infinity is:

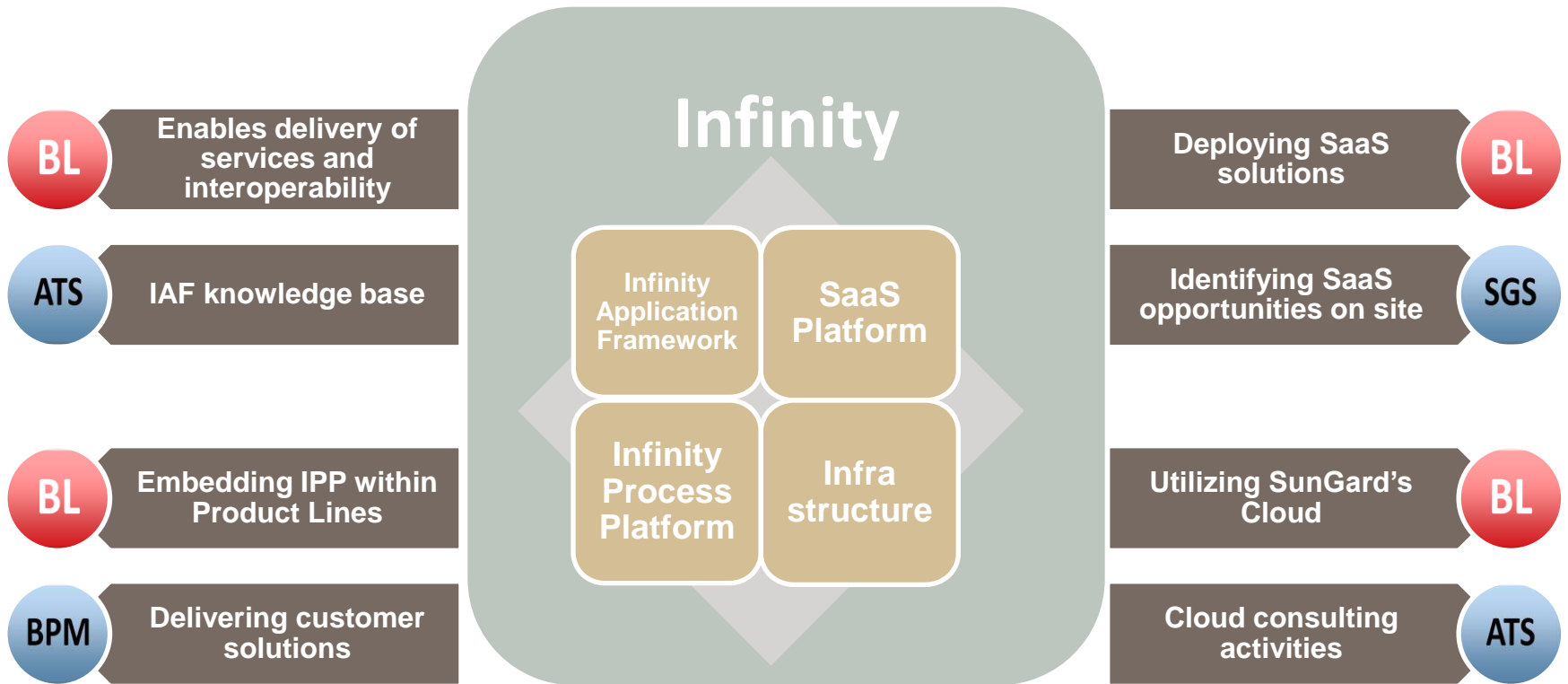

# How does Infinity Help SunGard Business Lines?

- Coding - Efficiently build the application
  - Leverage the Infinity Application Frameworks and IPP
- Storefront – Help business lines market a solution
  - Infinity SaaS Platform includes description, pricing and commercial models
- Procurement - Enable customers to select and purchase the solution
  - Process automated using Infinity SaaS Platform
  - Infinity Process Platform allows assembly of complex solutions

# How does Infinity Help SunGard Business Lines?

- Provisioning and Infrastructure – Provide a scalable infrastructure to run solution
  - Infinity Infrastructure provides “cloud” environment
- Billing - Meter service consumptions and bill for service
  - Usage detected via Infinity Application Frameworks
  - Billing records maintained by Infinity SaaS Platform

# Let's drill down

## End User Portal

with UI components from Infinity and integrated solutions

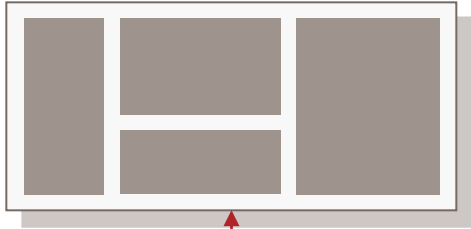

## End-to-end Value Chains for a Vertical

(e.g. Customer Onboarding, Corporate Actions, Payments)

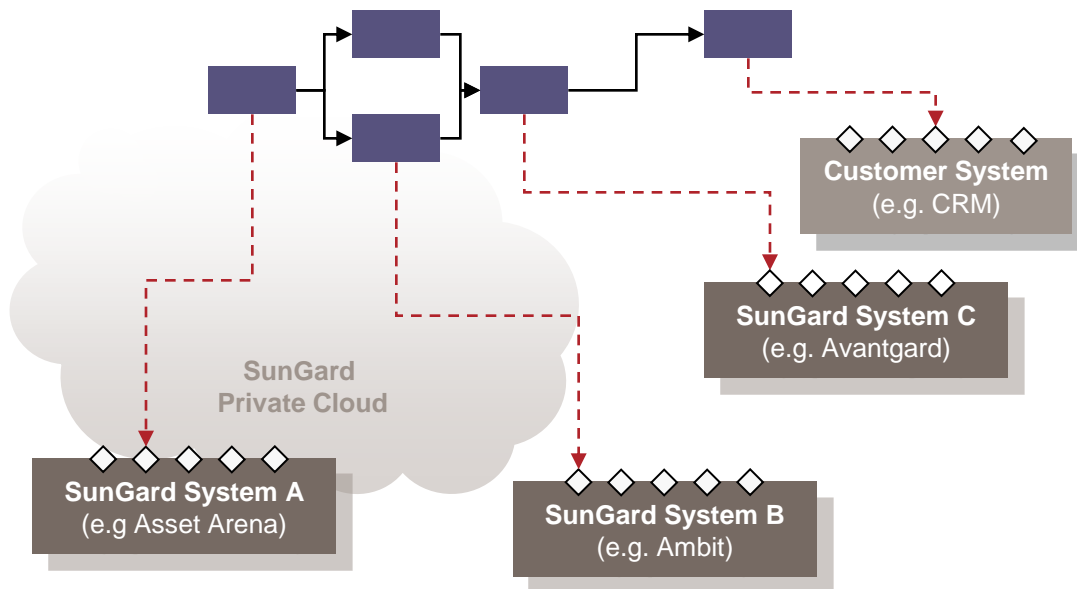

## Customer Benefits

Comprehensive support for relevant value chains across SunGard products and 3rd party solutions at the customer.

## Infinity Contribution

- Contains all artefacts needed to assemble end-to-end value chains
- Support for
  - Process Modeling
  - System Integration
  - UI Mashups
  - Document Management
- All components can be run "in the cloud"

# What we said in 2009:

## 2010 Roadmap

- Develop Cross-Segment Utilities
  - Reconciliation – first target

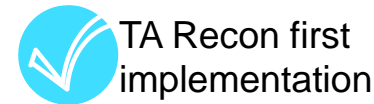

- Deliver further 30 solutions

- Ecosystem development

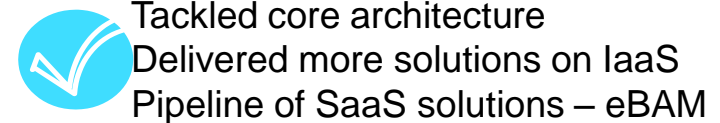

- Greater use of Cloud resources

- Self provisioning of infrastructure

- Policy based monitoring for dynamic and elastic solution scaling

- Reservations and bookings to ensure resource availability

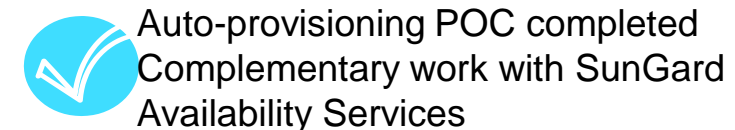

# Adoption Strategy in Action

---



# Corporations Business Line

## Market Factors

- Shift in control from Vendor to Customer to Community
- User centric apps that engage the user

## Technology Challenges

- Distributed global team
- Different Technology Stacks
- Old architectures

## Decision

- Take advantage of Global Services
- Leverage IAF and IPP
- Deliver small, consumable pieces of software as services

## Product Strategy

- New versions easier to host
- New SaaS development
- Services will work with
- Installed products

## Benefits

- Free up resources
- Pool of dynamic resources
- Same platform simplifies PS engagements

## Result

- Continue to support all product lines
- New offerings will be delivered as services

# AvantGard Composite Application based on Infinity Platform

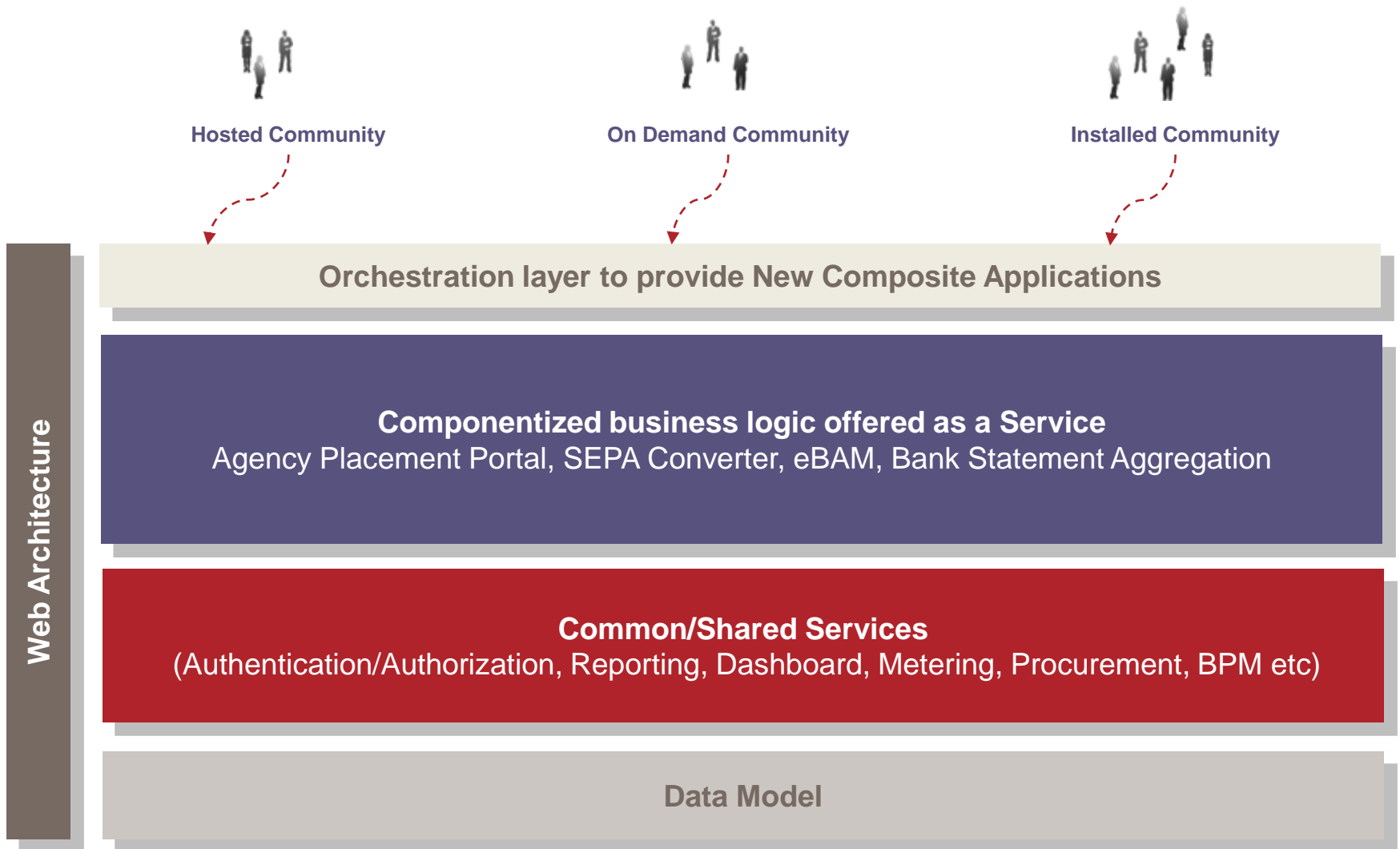

# Infinity-based Projects in Corporations Business

Project	Comments	Infinity Components
<p><b>Avantgard Agency Placement</b> helps improve and automate the collection of revenues that are assigned to collection agencies.</p>	Available via SaaS	<ul style="list-style-type: none"> <li>▪ IAF Java</li> <li>▪ Infinity SaaS Platform</li> <li>▪ IPP</li> <li>▪ Infrastructure</li> </ul>
<p><b>Avantgard SEPA Converter</b> provides payment conversion functionality to new customer segments who can benefit from making SEPA payments but would not implement a full Trax Payment Factory.</p>	Available via SaaS	<ul style="list-style-type: none"> <li>▪ IAF Java</li> <li>▪ Infinity SaaS Platform</li> <li>▪ IPP</li> <li>▪ Infrastructure</li> </ul>
<p><b>Avantgard GetPaid XE On Demand</b> provides services for working capital optimization delivered from SunGard infinity cloud.</p>	Available via SaaS	<ul style="list-style-type: none"> <li>▪ IAF Java</li> <li>▪ Infinity SaaS Platform</li> <li>▪ IPP</li> <li>▪ Infrastructure</li> </ul>
<p><b>Avantgard GetPaid Advanced Dispute</b> flexibility to customize the dispute process to match customer's internal workflow.</p>	Multi country roll out	<ul style="list-style-type: none"> <li>▪ IPP</li> <li>▪ IAF Java</li> <li>▪ Infrastructure</li> </ul>
<p><b>Electronic Bank Account Management (eBAM)</b> bank neutral, centralized portal to manage all of a corporation's bank account relationships.</p>	Service officially launched in EuroFinance in October 2010	<ul style="list-style-type: none"> <li>▪ IAF Java</li> <li>▪ Infinity SaaS Platform</li> <li>▪ IPP</li> <li>▪ Infrastructure</li> </ul>

# **Infinity On Demand – Platform as a Service**

---



# The Evolutionary Path into the Cloud

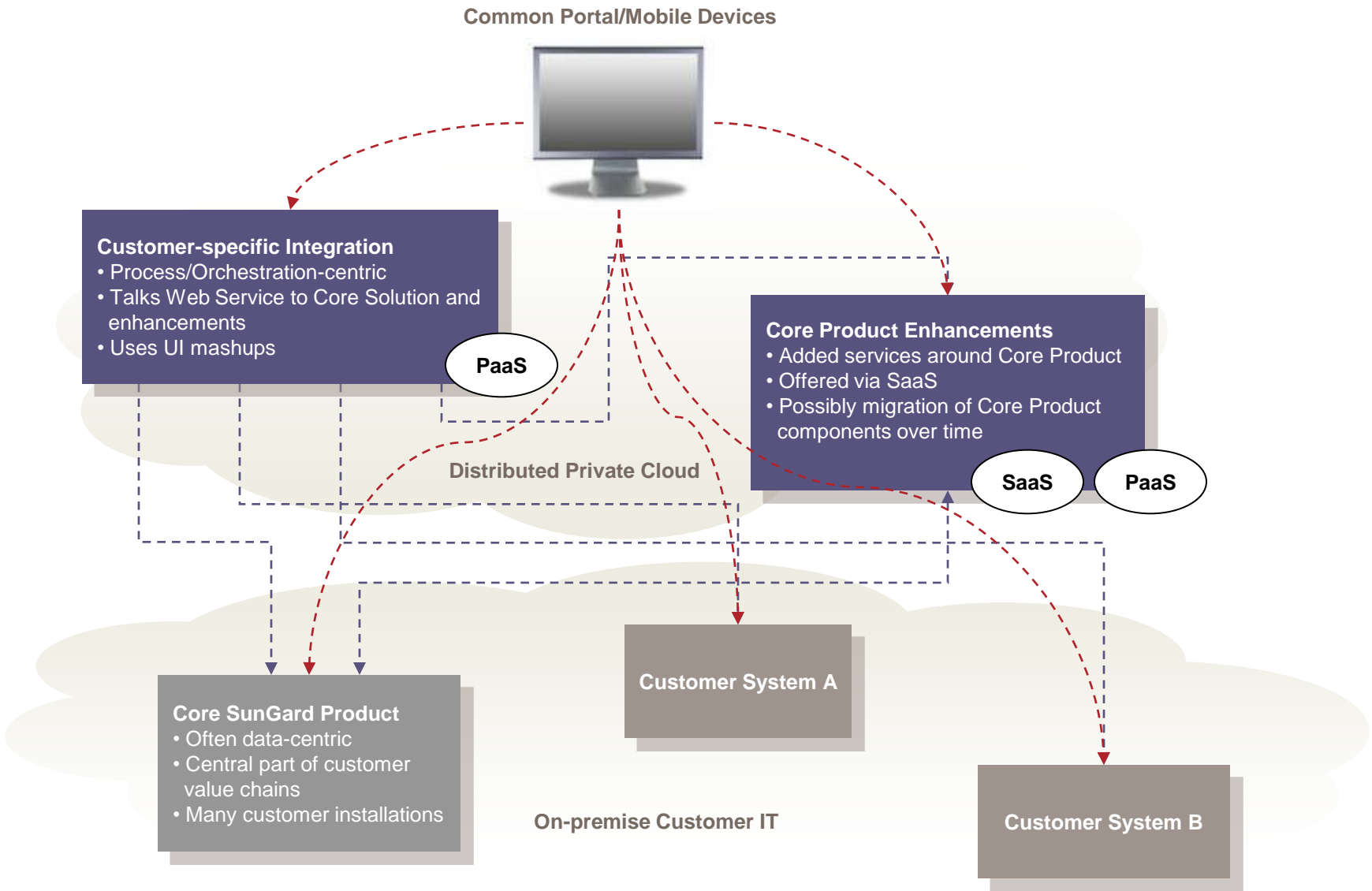

# Fast and Reliable Solution Delivery

- ①
- Infrastructure selection (Hardware, Operating System, Storage)
  - Selection of basic technologies (e.g. Database)
  - Selection of further components (e.g. Portal, BPM, User Management)
  - Solution logic development creates artefacts like database scripts, Java Bytecode, Process Models, Rules etc.
- ⇒ Recurring efforts with Solution Releases!

**Efforts saved**

Solution Provider



Infinity on Demand provides Platform as a Service (PaaS) with:

- a predefined and tested architecture and development methodology for solution development
- a lot of higher level services (Portal UI, BPM, Document Management, Service Management, Rules Management, ESB, Reporting etc.) to be used out-of-the-box by the solution
- runtime environments for this architecture and with these services on demand
- means to maintain solution instances independently of the underlying infrastructure



⇒ **Addresses projects on a 80/20 basis.**

Customer



Runtime Environments



Infrastructure Provider



Customer B

# XaaS Application Layering

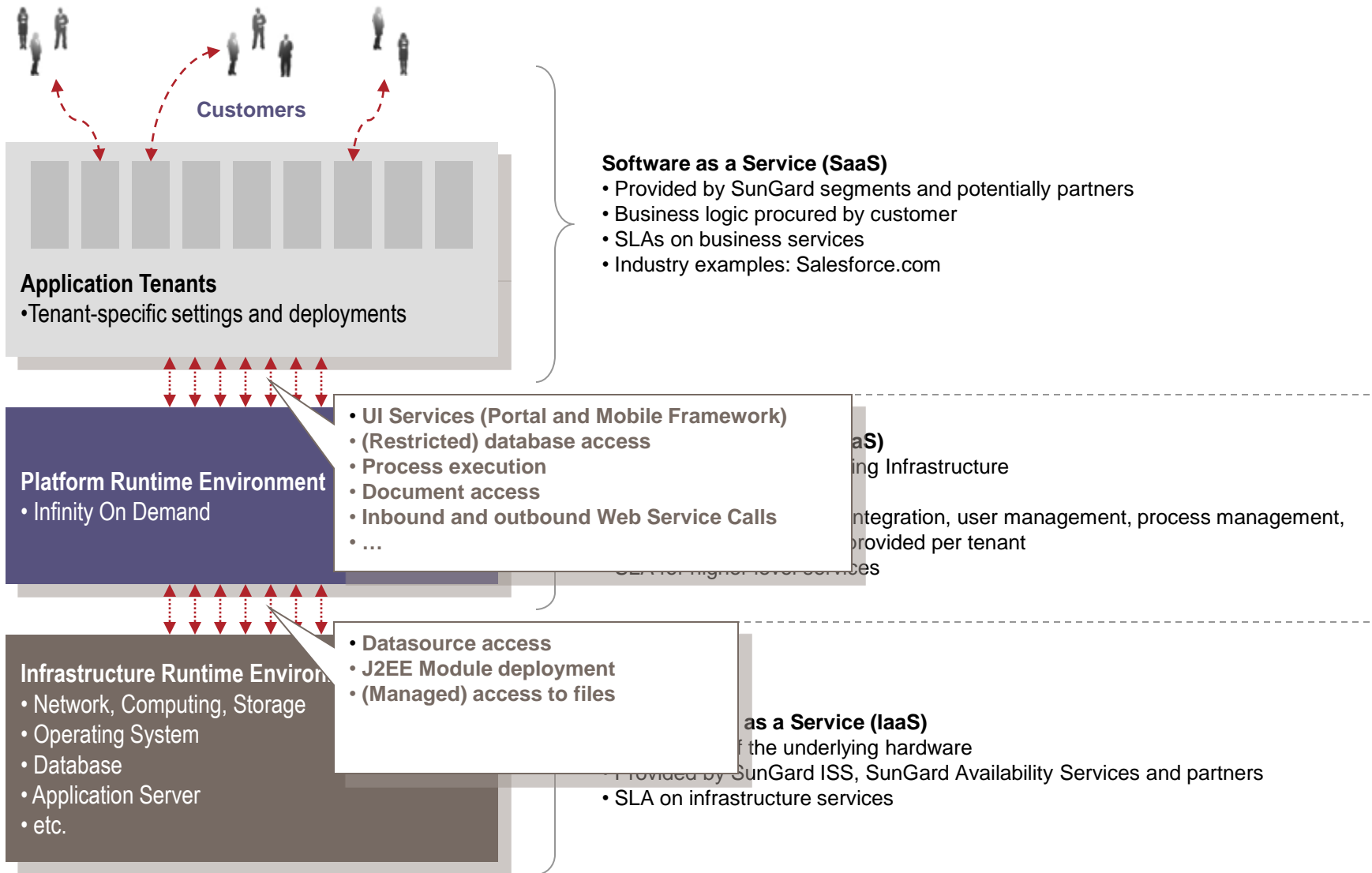

# Customer Benefits

- Infinity helps SunGard implement **end-to-end value chains** at their customers
- Infinity On Demand helps SunGard to roll out **additional product functionality** required by the customers
  - Quickly and reliably
- Infinity On Demand allows customers to run **integration projects** in the Cloud
- Leverages SunGard's proven track record in **data-center operations and availability services.**



# Example: SunGard Ambit Retail Banking

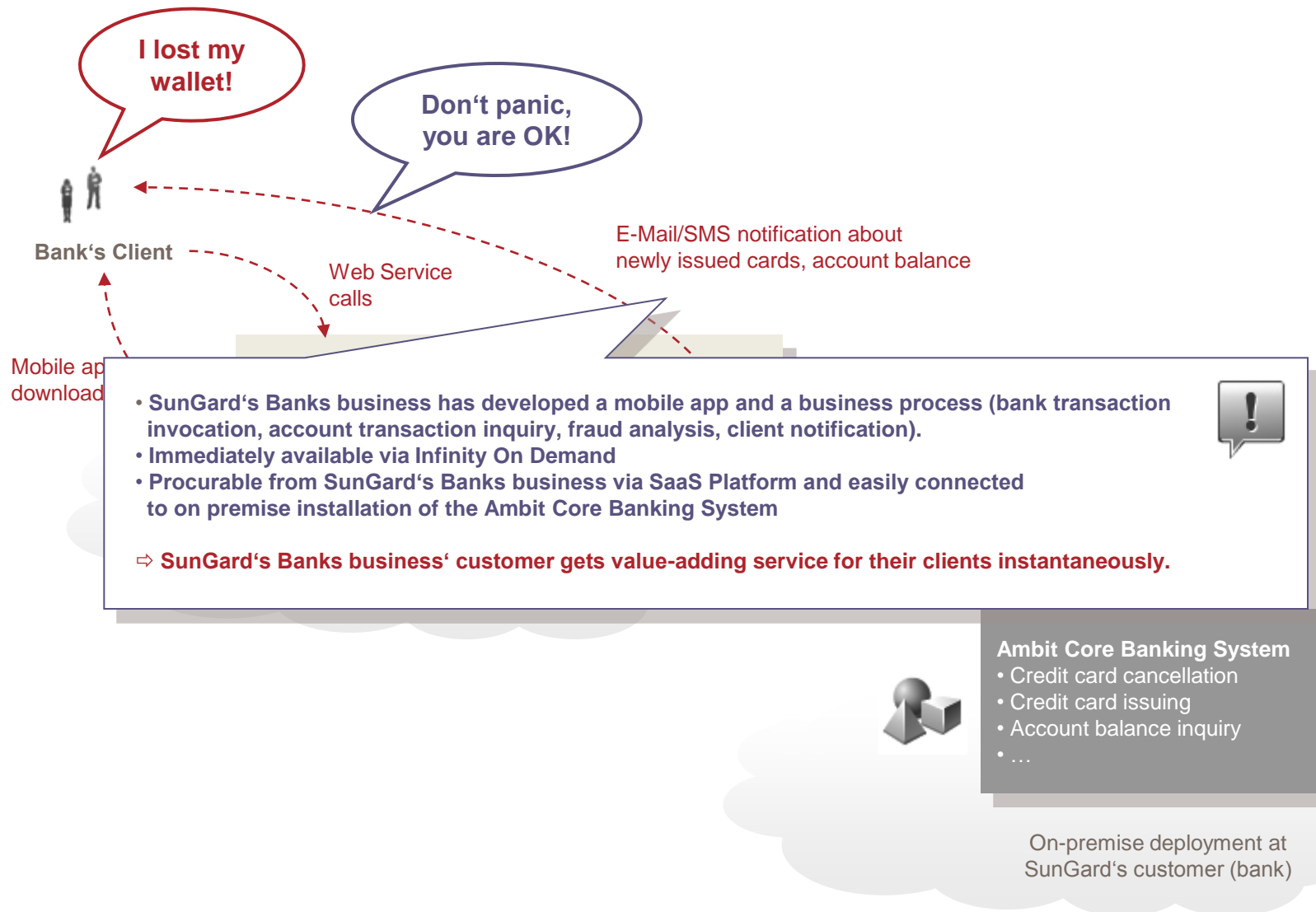

**What Next in 2011?**

---



# Forward looking

- PaaS Deployment
  - Continued development and deployment
- User Interface Framework
  - Standardized framework to unify experience
- Mobile Delivery
  - Additive and transformational solutions
- Ongoing SaaS and Ecosystem rollout
  - Meeting ongoing customer needs

# Questions

---



clare.porter@sungard.com  
marc.gille@sungard.com

# Confidentiality Statement

Copyright © 2010 by SunGard Data Systems Inc. (or its subsidiaries, “SunGard”). All rights reserved. No parts of this document may be reproduced, transmitted or stored electronically without SunGard’s prior written permission.

This document contains SunGard's confidential or proprietary information.

**By accepting this document, you agree that:** (A)(1) if a pre-existing contract containing disclosure and use restrictions exists between your company and SunGard, you and your company will use this information subject to the terms of the pre-existing contract; or (2) if no such pre-existing contract exists, you and your Company agree to protect this information and not reproduce or disclose the information in any way; and (B) SunGard makes no warranties, express or implied, in this document, and SunGard shall not be liable for damages of any kind arising out of use of this document.